

W 9 L: Laser photoelectric switches: small, light and reliable



- Through-beam photoelectric switch with simple Teach-in operation,
- Temperature-compensated laser-protection electronics make constant performance of the laser possible in laser protection class 2.

Objects as small as hairs are detected just as reliably as fast operations are processed. Interference from external light sources is ignored, and cell phones are not detected. Innovative Teach-in technology means a simple push of a button for operating the W 9 Laser series.

To ensure that the W 9 Laser series can be used without problems in the whole world, we have complied with all regulations and fulfilled all standards, for example, CE and CDRH.

The W 9 Laser series provides a complete series with innovative laser technology in compact plastic housing.

Because our devices are controlled using the most modern μP technology, we can provide a laser series that has excellent performance data in addition to its small size and slight weight.

- Proximity switch with background suppression, which can be set very precisely,
- Photoelectric switch with simple Teach-in operation,

	Photoelectric proximity switches, BGS
	Photoelectric reflex switches
	Through-beam photoelectric switches

Scanning distance
150 mm

Photoelectric proximity switches

- Laser red light, class 2
- Background suppression adjustable
- Switching frequency 1000/s
- Compact housing made of ABS

Dimensional drawing

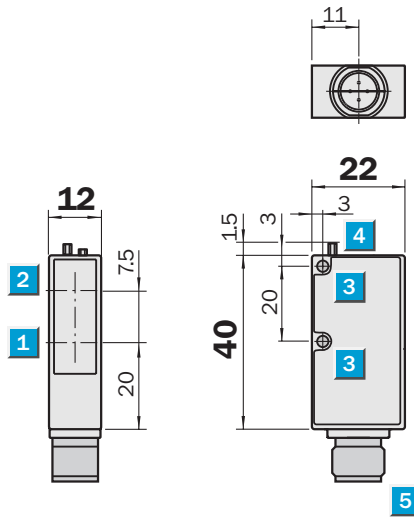

Adjustments possible

WT 9L-P330
WT 9L-P430
WT 9L-N330
WT 9L-N430

- 1** Centre of optical axis, sender
- 2** Centre of optical axis, receiver
- 3** Mounting hole \varnothing 3.2 mm
- 4** Power indicator green;
LED signal strength indicator yellow
- 5** Plug M12 or M8, 4-pin
- 6** Scanning distance adjustment

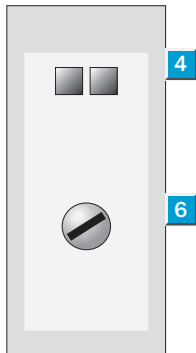

Connection types

WT 9L-P330	WT 9L-P430
WT 9L-N330	WT 9L-N430

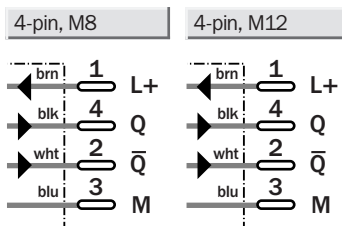
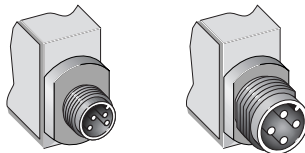

Accessories

Connectors
Mounting systems

Technical data		WT 9L-	P330	P430	N330	N430						
Scanning distance ¹⁾	30 ... 150 mm, adjustable											
Supply voltage V_S	10 ... 30 V DC ²⁾											
Ripple ³⁾	< 5 V_{pp}											
Current consumption ⁴⁾	< 35 mA											
Light source ⁵⁾ , light type	Laser, red light; class 2											
Focusing position/light spot diameter	60 mm/< 0.5 mm											
Switching outputs Q and \bar{Q}	PNP											
	NPN											
PNP; signal voltage HIGH	$V_S - 2$ V											
PNP; signal voltage LOW	Approx. 0 V											
NPN; signal voltage HIGH	V_S											
NPN; signal voltage LOW ⁶⁾	$V_S < 2$ V											
Output current I_A max.	< 100 mA											
Response time ⁷⁾	< 0.6 ms											
Max. switching frequency ⁸⁾	1000/s											
Connection types	Plug M12, 4-pin											
	Plug M8, 4-pin											
VDE protection class ⁹⁾	II (plug M12)											
	III (plug M8)											
Enclosure rating	IP 67											
Circuit protection ¹⁰⁾	A, B, C											
Ambient temperature T_A ¹¹⁾	Operation - 10 ... + 50 °C											
	Storage - 25 ... + 70 °C											
Weight with plug	Approx. 20 g											
Housing material	ABS											

¹⁾ Object with 90 % remission (based on standard white DIN 5033)
²⁾ Limit values
³⁾ May not exceed or fall short of V_S tolerances
⁴⁾ Without load

⁵⁾ Average service life 50,000 h at $T_A = + 25$ °C
⁶⁾ At $T_A = + 25$ °C and 100 mA output current
⁷⁾ Signal transit time with resistive load
⁸⁾ With light/dark ratio 1:1

⁹⁾ Reference voltage 50 V
¹⁰⁾ A = V_S connections reverse-polarity protected
 B = Outputs reverse-polarity protected
 C = Interference pulse suppression

¹¹⁾ Do not stack devices

Laser protection

EN 60825-1, class 2
 CDRH 1040.10, class 2

Scanning distance

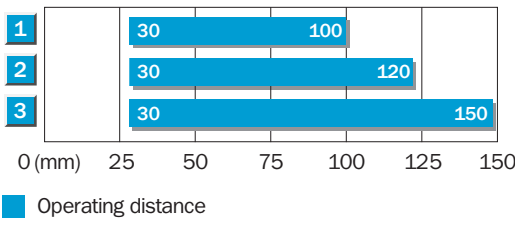

- 1 Scanning range on black, 6 % remission
- 2 Scanning range on grey, 18 % remission
- 3 Scanning range on white, 90 % remission

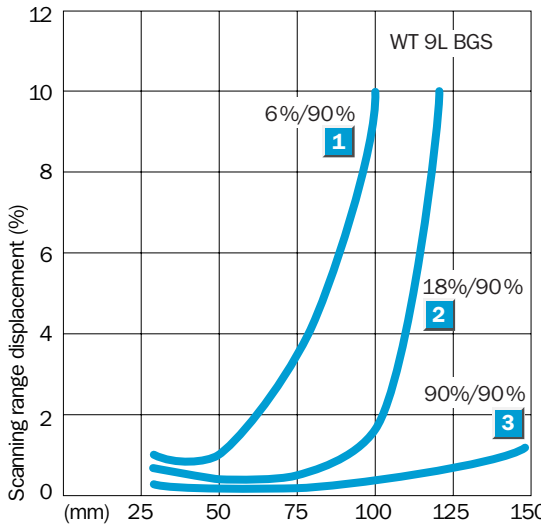

Order information

Type	Part no.
WT 9L-P330	1 023 977
WT 9L-P430	1 023 959
WT 9L-N330	1 023 991
WT 9L-N430	1 023 990

Scanning range
12 m

Photoelectric reflex switches

- Laser red light, class 2
- Teach-in
- Switching frequency 1000/s
- Polarising filter
- Compact housing made of ABS

Dimensional drawing

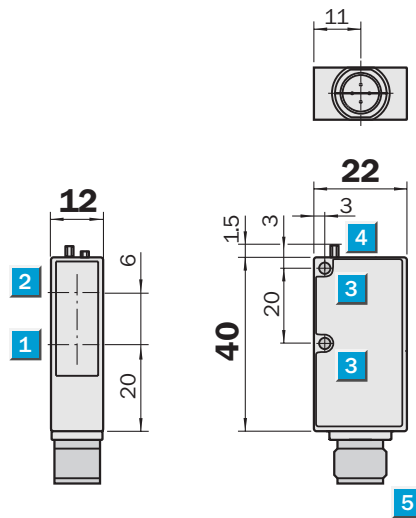

Adjustments possible

- WL 9L-P330
- WL 9L-P430
- WL 9L-N330
- WL 9L-N430

- 1 Centre of optical axis, sender
- 2 Centre of optical axis, receiver
- 3 Mounting hole \varnothing 3.2 mm
- 4 Power indicator green;
LED signal strength indicator yellow
- 5 Plug M12 or M8, 4-pin
- 6 Teach-in button

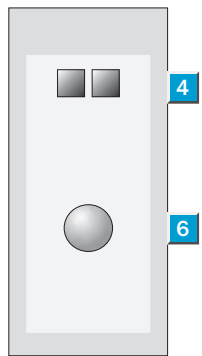

Connection types

- | | |
|------------|------------|
| WL 9L-P330 | WL 9L-P430 |
| WL 9L-N330 | WL 9L-N430 |

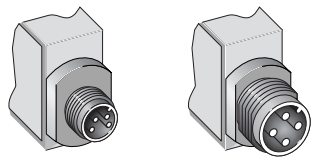

4-pin, M8

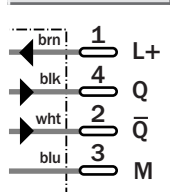

4-pin, M12

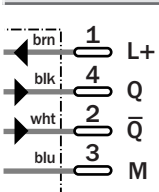

- Accessories**
- Connectors
 - Mounting systems



Technical data	WL 9L-	P330	P430	N330	N430						
Scanning range, max. typ./on Reflector	0.1–12 m/PL 80 A										
Supply voltage V_S	10 ... 30 V DC ¹⁾										
Ripple ²⁾	< 5 V_{pp}										
Current consumption ³⁾	< 35 mA										
Light source ⁴⁾ , light type	Laser 650 nm, red, class 2										
Focusing position/light spot diameter	∞ / $<$ 1 mm in 100 mm										
Switching outputs Q and \bar{Q}	PNP										
	NPN										
PNP; signal voltage HIGH	$V_S - 2$ V										
PNP; signal voltage LOW	Approx. 0 V										
NPN; signal voltage HIGH	V_S										
NPN; signal voltage LOW ⁵⁾	$V_S - 2$ V										
Output current I_A max.	< 100 mA										
Response time ⁶⁾	< 0.6 ms										
Max. switching frequency ⁷⁾	1000/s										
Connection types	Plug M12, 4-pin										
	Plug M8, 4-pin										
VDE protection class ⁸⁾	□ (plug M12)										
	III (plug M8)										
Enclosure rating	IP 67										
Circuit protection ⁹⁾	A, B, C										
Ambient temperature T_A ¹⁰⁾	Operation - 10 ... + 50 °C										
	Storage - 25 ... + 75 °C										
Weight with plug	Approx. 20 g										
Housing material	ABS										

¹⁾ Limit values
²⁾ May not exceed or fall short of V_S tolerances
³⁾ Without load

⁴⁾ Average service life 50,000 h at $T_A = + 25$ °C
⁵⁾ At $T_A = + 25$ °C and 100 mA output current

⁶⁾ Signal transit time with resistive load
⁷⁾ With light/dark ratio 1:1
⁸⁾ Reference voltage 50 V

⁹⁾ A = V_S connections reverse-polarity protected
 B = Outputs reverse-polarity protected
 C = Interference pulse suppression
¹⁰⁾ Do not stack devices

Teach-in function standard

- Align the photoelectric switch with the reflector. LED yellow/green = on.
- Press Teach-in button > 2 s. LED green = off/on. Teach-in is initiated. LED yellow/green = blinking.
- The signal is stored permanently after you release the button. The switching threshold is set to standard sensitivity.

Precise setting:

- Align the photoelectric switch with the reflector. LED yellow/green = on.
- Press Teach-in button > 5 s. LED green = off/on. Teach-in is initiated. LED yellow/green = blinking.
- The signal is stored permanently after you release the button. The switching threshold is set to a low degree of sensitivity (detection of transparent objects is possible).

Laser protection

EN 60825-1, class 2
 CDRH 1040.10, class 2

Scanning range

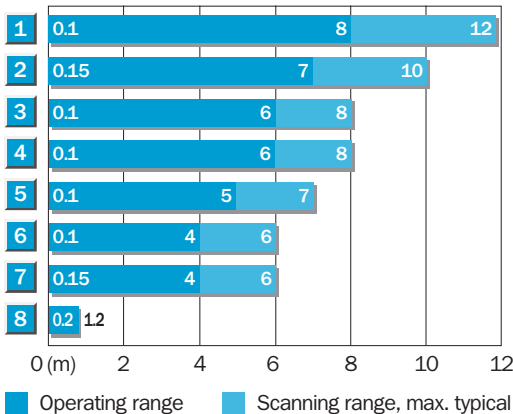

Reflector type	Operating range
1 PL 80 A	0 - 8.0 m
2 PL 250 F	0 - 7.0 m
3 PL 50 A	0 - 6.0 m
4 PL 40 A	0 - 6.0 m
5 PL 30 A	0 - 5.0 m
6 PL 20 A	0 - 4.0 m
7 PL 20 F	0 - 4.0 m
8 Reflective tape	0 - 1.2 m

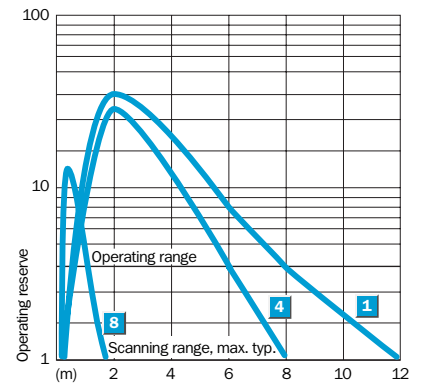

Order information

Type	Part no.
WL 9L-P330	1 023 976
WL 9L-P430	1 023 958
WL 9L-N330	1 023 989
WL 9L-N430	1 023 988

Scanning range
0 ... 50 m

Through-beam photoelectric switches

- Laser red light, class 2
- Teach-in
- Switching frequency 1000/s
- Compact housing made of ABS

Dimensional drawing

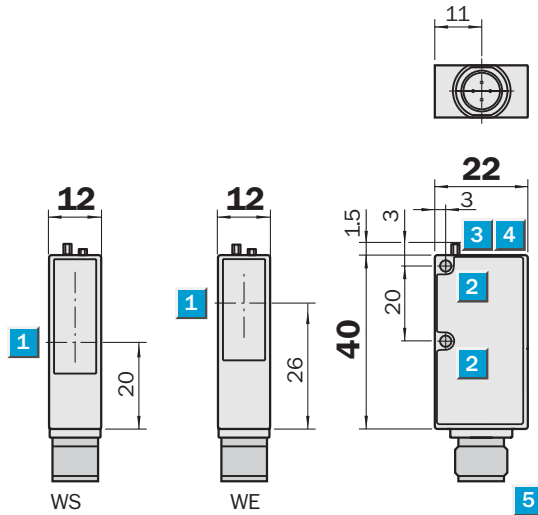

Adjustments possible

WS/WE 9L-P330	WS/WE 9L-N330
WS/WE 9L-P430	WS/WE 9L-N430

- 1 Centre of optical axis
- 2 Mounting hole \varnothing 3.2 mm
- 3 Power indicator green, WS in operation
- 4 LED signal strength indicator yellow
- 5 Plug M12 or M8, 4-pin
- 6 Teach-in button

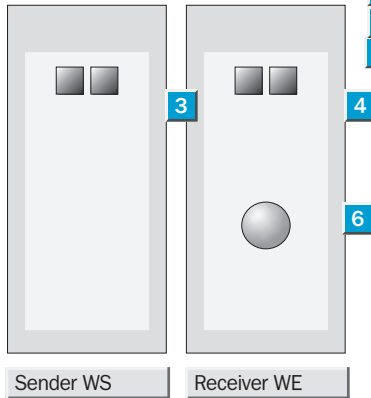

Connection types

WS/WE 9L-P330	WS/WE 9L-P430
WS/WE 9L-N330	WS/WE 9L-N430



CE CDRH

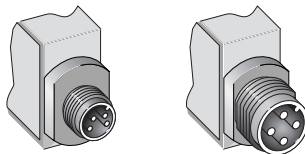

4-pin, M8 4-pin, M12

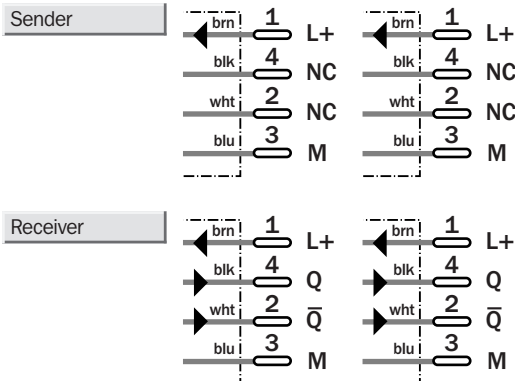

Accessories

Connectors
Mounting systems

Technical data		WS/WE 9L-	P330	P430	N330	N430						
Scanning range, max. typ.	50 m											
Supply voltage V_s	10 ... 30 V DC ¹⁾											
Ripple ²⁾	< 5 V _{pp}											
Current consumption ³⁾	< 25 mA (WE), < 35 mA (WS)											
Light source ⁴⁾ , light type	Laser, red, class 2											
Focusing position/light spot diameter	500 mm/< 0.5 mm											
Switching outputs Q and \bar{Q}	PNP											
	NPN											
PNP; signal voltage HIGH	$V_s - 2$ V											
PNP; signal voltage LOW	Approx. 0 V											
NPN; signal voltage HIGH	V_s											
NPN; signal voltage LOW ⁵⁾	$V_s - 2$ V											
Output current I_A max.	< 100 mA											
Response time ⁶⁾	< 0.6 ms											
Max. switching frequency ⁷⁾	1000/s											
Connection types	Plug M12, 4-pin											
	Plug M8, 4-pin											
VDE protection class ⁸⁾	□ (plug M12)											
	III (plug M8)											
Enclosure rating	IP 67											
Circuit protection ⁹⁾	A, B, C											
Ambient temperature T_A ¹⁰⁾	Operation - 10 ... + 50 °C											
	Storage - 25 ... + 70 °C											
Weight with plug	Approx. 20 g											
Housing material	ABS											

¹⁾ Limit values
²⁾ May not exceed or fall short of V_s tolerances
³⁾ Without load
⁴⁾ Average service life 50,000 h at $T_A = + 25$ °C
⁵⁾ At $T_A = + 25$ °C and 100 mA output current
⁶⁾ Signal transit time with resistive load
⁷⁾ With light/dark ratio 1:1
⁸⁾ Reference voltage 50 V
⁹⁾ A = V_s connections reverse-polarity protected
 B = Outputs reverse-polarity protected
 C = Interference pulse suppression
¹⁰⁾ Do not stack devices

Teach-in function standard

- Align the sender and receiver with respect to each other. Receiver LED yellow/green = on.
- Press Teach-in button > 2 s. LED green = off/on. Teach-in is initiated. LED yellow/green = blinking.
- The signal is stored permanently after you release the button. The switching threshold is set to standard sensitivity.

Precise setting:

- Align the sender and receiver with respect to each other. Receiver LED yellow/green = on.
- Press Teach-in button > 5 s. LED green = off/on. Teach-in is initiated. LED yellow/green = blinking.
- The signal is stored permanently after you release the button. The switching threshold is set to a low degree of sensitivity (detection of transparent objects is possible).

Laser protection

EN 60825-1, class 2
 CDRH 1040.10, class 2

Scanning range

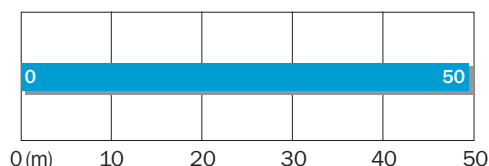

Operating range/Scanning range, max. typical

Order information

Type	Part no.
WS/WE 9L-P330	1 023 993
WS/WE 9L-P430	1 023 992
WS/WE 9L-N330	1 023 995
WS/WE 9L-N430	1 023 994

Dimensional drawings and order information

Plastic design for temperatures up to 65 °C

Reflector, Ø 22 mm, plug-in style	
Type	Part no.
PL 22-1	1 003 546

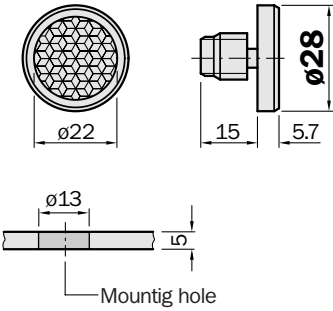

Reflector, Ø 22 mm self-adhesive	
Type	Part no.
PL 22-2	1 003 621

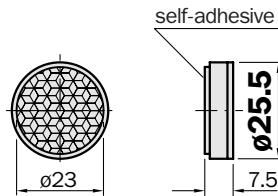

Reflector 20 x 40 mm ²	
Type	Part no.
PL 20 A	1 012 719

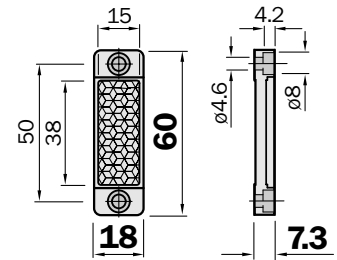

Reflector 20 x 40 mm ² micro triple, 2 hole mounting	
Type	Part no.
PL 20 F	5 308 844

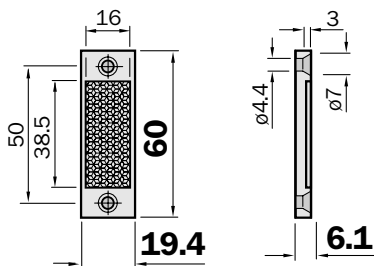

Reflector 30 x 50 mm ²	
Type	Part no.
PL 30 A	1 002 314

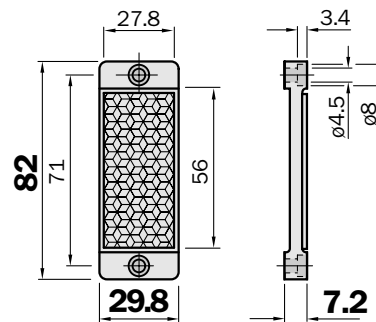

Reflector 40 x 60 mm ²	
Type	Part no.
PL 40 A	1 012 720

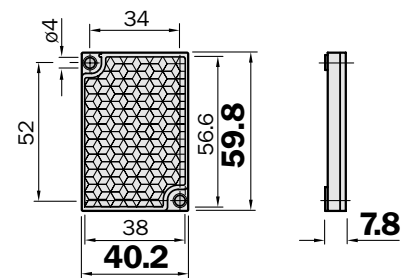

Reflector 6-sided, width across flats 48 mm	
Type	Part no.
PL 50 A	1 000 132

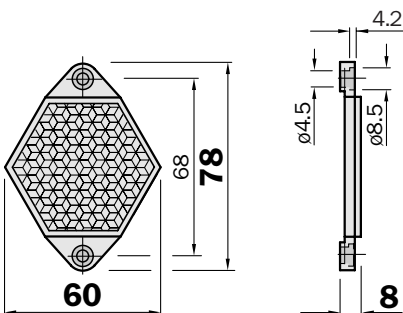

Reflector 80 x 80 mm ²	
Type	Part no.
PL 80	1 003 865

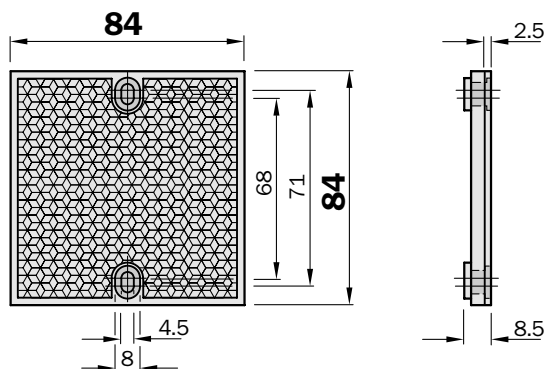

Also available in heatable model:
 Permanent heating: PL 50HK, part no. 1 001 545
 Controlled heating: PL 50HS, part no. 1 009 871

Dimensional drawings and order information

Plastic design for temperatures up to 65 °C

Reflector 47 x 47 mm²

micro triple, 2 hole mounting

Type	Part no.
P 250 F	5 308 843

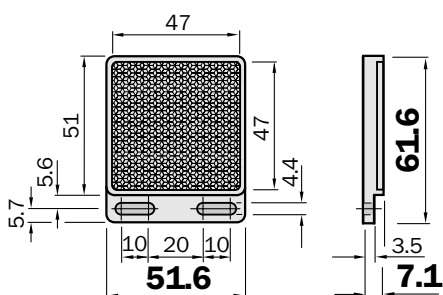

Reflector 20 x 20 mm²

Type	Part no.
PL 10 F	5 311 210

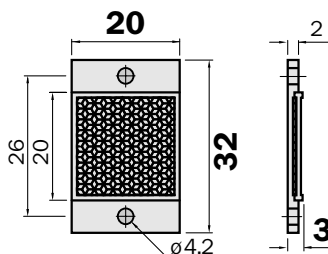

Reflective tape "Diamond Grade"

Cut to size, sheet 749 x 914 mm²

Type	Part no.
REF-DG-K	4 019 634
REF-DG	5 304 334



SENSICK screw-in system M12, 4-pin, enclosure rating IP 67

Female connector M12, 4-pin, straight

Type	Part no.	Contacts	Can be adapted for cables Ø 4.5 to 6.5 mm
DOS-1204-G	6 007 302	4	

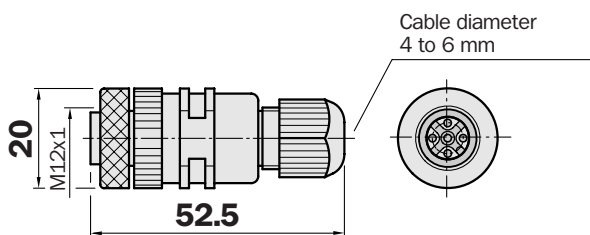

Female connector M12, 4-pin, right angle

Type	Part no.	Contacts	Can be adapted for cables Ø 4.5 to 6.5 mm
DOS-1204-W	6 007 303	4	

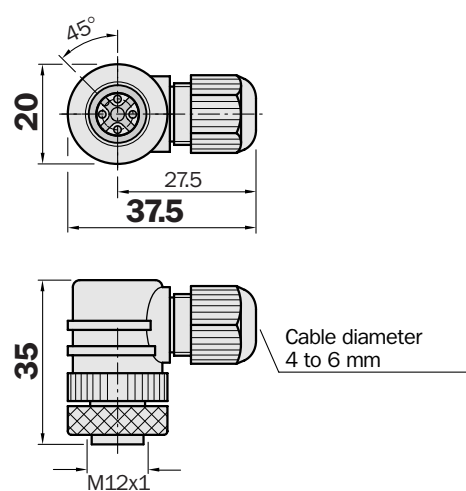

SENSICK screw-in system M8, 4-pin, enclosure rating IP 67

Female connector M8, 4-pin, straight

Type	Part no.
DOS-0804-G	6 009 974

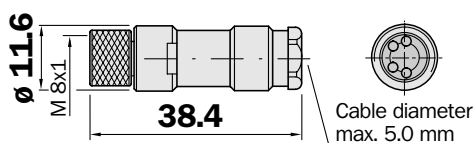

Female connector M8, 4-pin, right angle

Type	Part no.
DOS-0804-W	6 009 975

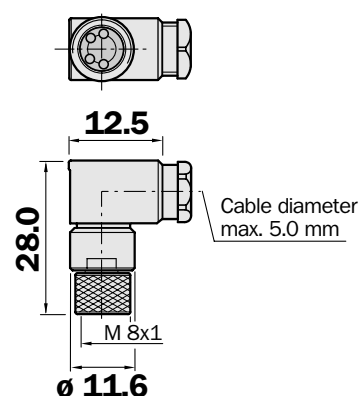

Dimensional drawings and order information

SENSICK screw-in system M8, 4-pin, enclosure rating IP 67

Female connector M8, 4-pin, straight

Cable diameter 5 mm, 4 x 0.25 mm², sheath PVC

Type	Part no.	Cable length
DOL-0804-G02M	6 009 870	2 m
DOL-0804-G05M	6 009 872	5 m
DOL-0804-G10M	6 010 754	10 m

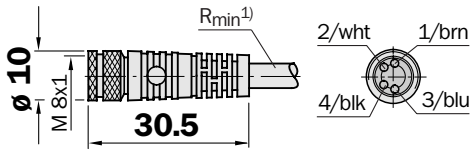

Female connector M8, 4-pin, right angle

Cable diameter 5 mm, 4 x 0.25 mm², sheath PVC

Type	Part no.	Cable length
DOL-0804-W02M	6 009 871	2 m
DOL-0804-W05M	6 009 873	5 m
DOL-0804-W10M	6 010 755	10 m

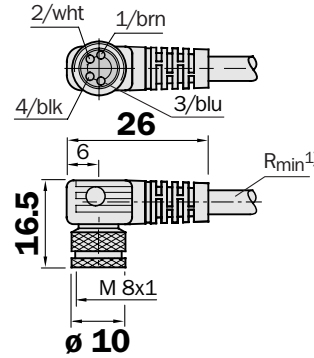

¹⁾ Minimum bend radius in dynamic use
 $R_{min} = 20 \times \text{cable diameter}$

SENSICK screw-in system M12, 4-pin, enclosure rating IP 67

Female connector M12, 4-pin, straight

Cable diameter 5 mm, 4 x 0.25 mm², sheath PVC

Type	Part no.	Contacts	Cable length
DOL-1204-G02M	6 009 382	4	2 m
DOL-1204-G05M	6 009 866	4	5 m
DOL-1204-G10M	6 010 543	4	10 m
DOL-1204-G15M	6 010 753	4	15 m

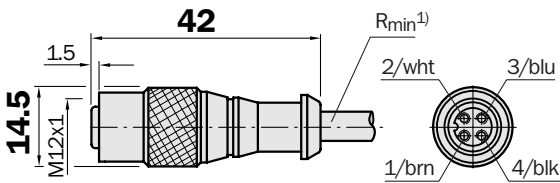

Female connector M12, 4-pin, right angle

Cable diameter 5 mm, 4 x 0.25 mm², sheath PVC

Type	Part no.	Contacts	Cable length
DOL-1204-W02M	6 009 383	4	2 m
DOL-1204-W05M	6 009 867	4	5 m
DOL-1204-W10M	6 010 541	4	10 m

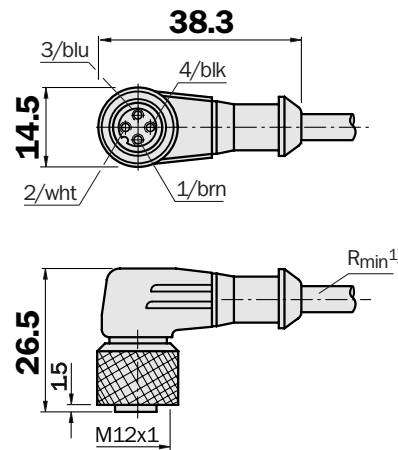

Dimensional drawings and order information

SENSICK screw-in system M12, 4-pin, enclosure rating IP 67

Female connector M12, 4-pin, right angle

Cable diameter 5 mm, 4 x 0.34 mm², sheath PUR/PVC

With built-in LED-operation and function indicators, PNP complementary ²⁾

Type	Part no.	Contacts	Cable length
DOL-1204-W05ME	6 020 398	4	5 m

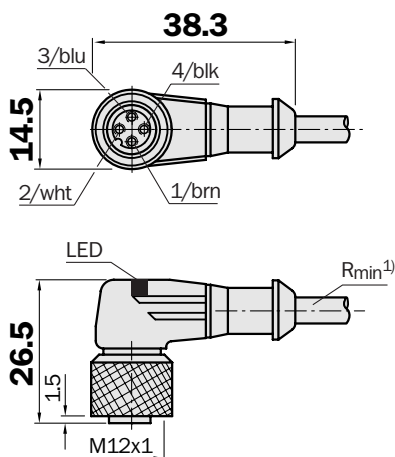

¹⁾ Minimum bend radius in dynamic use

$R_{min} = 20 \times \text{cable diameter}$

²⁾ Note: Not suitable for sender in through-beam photoelectric switches

Mounting bracket

Type	Part no.
BEF-WN-W9-2	2 022 855

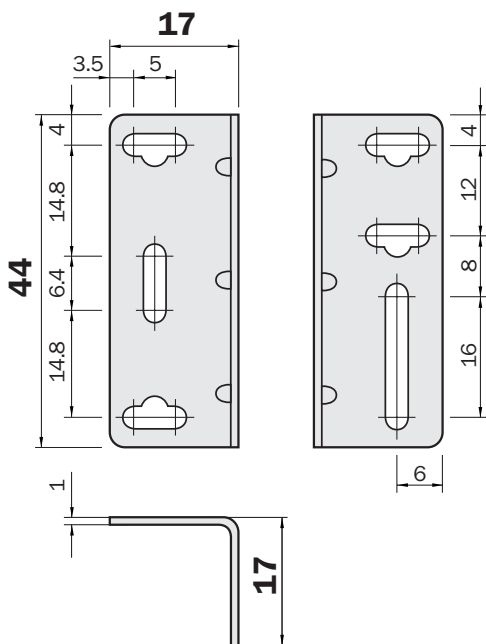

Your contacts:

Australia

Phone +61 3 94 97 41 00
008 33 48 02 – toll free
Fax +61 3 94 97 11 87

Austria

Phone +43 2 23 66 22 88-0
Fax +43 2 23 66 22 88-5

Belgium/Luxembourg

Phone +32 24 66 55 66
Fax +32 24 63 31 04

Brazil

Phone +55 11 55 61 26 83
Fax +55 11 55 35 41 53

China

Phone +8 52 27 63 69 66
Fax +8 52 27 63 63 11

Czech Republik

Phone +42 02 578 10 561
Fax +42 02 578 10 559

Denmark

Phone +45 45 82 64 00
Fax +45 45 82 64 01

Finland

Phone +3 58 9-7288500
Fax +3 58 9-72885055

France

Phone +33 1 64 62 35 00
Fax +33 1 64 62 35 77

Germany

Phone +49 2 11 53 01 0
Fax +49 2 11 53 01 100

Great Britain

Phone +44 17 27-83 11 21
Fax +44 17 27-85 67 67

Italy

Phone +39 02 92 14 20 62
Fax +39 02 92 14 20 67

Japan

Phone +813 33 58 13 41
Fax +813 33 58 90 48

Korea

Phone +82 2 786 63 21/4
Fax +82 2 786 63 25

Netherlands

Phone +31 30 229 25 44
Fax +31 30 229 39 94

Norway

Phone +47 67 56 75 00
Fax +47 67 56 66 10

Poland

Phone +48 22 8 37 40 50
Fax +48 22 8 37 43 88

Singapore

Phone +65 67 44 37 32
Fax +65 68 41 77 47

Spain

Phone +34 93 4 80 31 00
Fax +34 93 4 73 44 69

Sweden

Phone +46 8 6 80 64 50
Fax +46 8 7 10 18 75

Switzerland

Phone +41 4 16 19 29 39
Fax +41 4 16 19 29 21

Taiwan

Phone +88 62 23 65 62 92
Fax +88 62 23 68 73 97

USA/Canada/Mexico

Phone +1(952) 9 41-67 80
Fax +1(952) 9 41-92 87

Representatives and agencies
in all major industrial nations.

SICK